

CNC lathe TC30 II MC×1500

(FANUC-0i TF-β5×3500rpm)

(Version: 20220225)

Technical File

Content

Technology Agreement including the followings:

A.	Main Features.....	1
B.	Main technical parameters	3
C.	Machine configuration	4
D.	Purchased Components list	5
E.	Installation Preparation Form	6
F.	Recommended Oil and Grease Tables	7
G.	Acceptance accuracy table	8

A. Main Features



(notice: the picture only for reference)

- Double row cylindrical roller bearings and high speed thrust angular contact ball bearings are adopted in the front of the spindle, and double row cylindrical roller bearings are adopted in the rear
- 45 ° one-piece casting lathe bed with box way
- Independent tailstock, hydraulic drives sleeve
- 12 station hydraulic turret
- The motor directly drives ball screw, with pre-stretching
- Thin oil lubrication
- Full enclosure
- **Power & Torque**

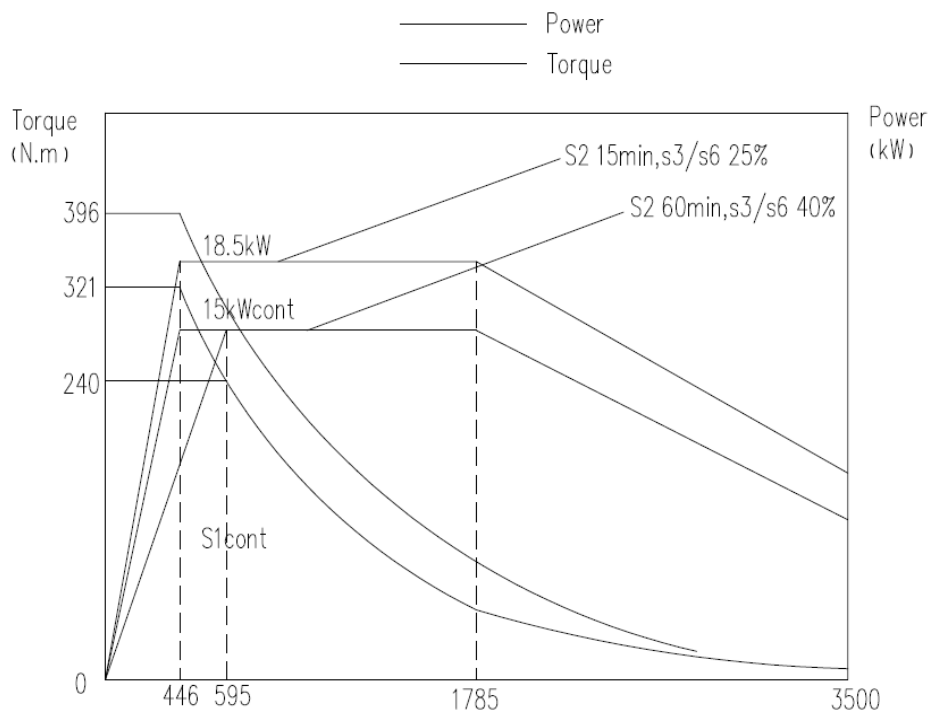

- **Power turret milling axis**

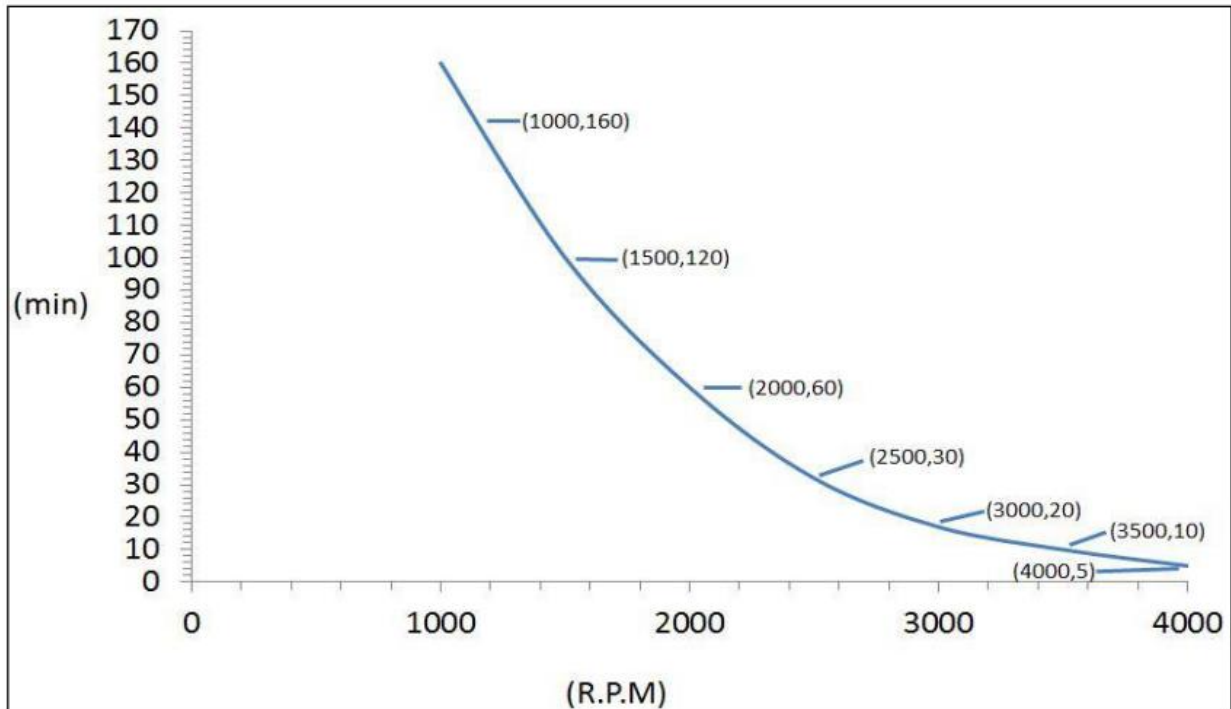

- **Installation conditions**

1. Temperature

Working temperature: $17^{\circ}\text{C}\sim 25^{\circ}\text{C}$, $\pm 2^{\circ}\text{C}$

If the requirements of the processed parts are not so precision, the ambient temperature range could be relaxed to.

When storing and transporting: $-30^{\circ}\text{C}\sim 50^{\circ}\text{C}$

2. Humidity

Continuous: Under 75%(No condensation)

Short time: Under 95%(No condensation)

3. Installation site conditions

- 1). Not affected by external vibration and electrical interference

- 2). Avoid direct sunlight to the machine tool

- 3). Avoid direct contact with outside wind, air, and temperature-adjusted cold and hot air

- 4). Avoid setting up heating and other heat sources near the machine tool

- 5). The concentration of dust in the air shall not be greater than $10\text{mg}/\text{m}^3$, and should not contain acid, salt and other corrosive gases.

- 6). Avoid water leakage and flooding

B. Main technical parameters

Item			Parameters
Machining scope	Max. swing over the bed	mm	Φ650
	Max. swing over the saddle	mm	Φ420
	Max. turning dia	mm	Φ450
	Max. turning length	mm	920
	Spindle center according to height	mm	1030
	X stroke	mm	253
	Z stroke	mm	970
Power turret	Turret type	-	BMT65(12T)
	OD size	mm	25×25
	ID size	mm	Φ40
	Indexing time(T-T)	s	0.57
Spindle	Drive type	-	Belt spindle
	Max. spindle speed	rpm	3500
	Power (Con./15 minutes)	kW	15/18.5
	Spindle nose	-	JISA2-8
	Spindle through hole	mm	Φ76
	Max. bar capacity	mm	Φ65
	Spindle bearing dia(front)	mm	Φ120
	Chuck size	inch	10
	Max. drilling dia	mm	Φ20
	Max. milling axis tapping size	mm	M14×2 or M20×1.5
	Max. extension length of tool	mm	50
	Milling axis transmission ratio	-	1:1
	Milling axis power	kW	3.7/5.5
	Milling axis torque(cont/max)	Nm	23.6/35
	Max. milling axis spindle speed	rpm	4000
Feed	X/Z rapid feed	m/min	16/20
	X/Z servo motor power	kW	2.5/2.5
Tailstock	Quill dia	mm	Φ100
	Center type	-	MT NO.5
	Quill stroke	mm	120
	Stroke	mm	730
Controller			FANUC 0i-TF(β5)
Power supply		kVA	35
Water tank capacity		L	250
Machine weight		t	5.4
Machine size (Length×width×height)		mm	4600×2050×2050

C. Machine configuration

Standard configuration

1.	Controller: FANUC 0i TF	11.	Foot switch
2.	Hydraulic system	12.	Working light
3.	Cutting coolant system	13.	Door interlock
4.	Lubrication system	14.	Leveling blocks
5.	Full enclosure with top cover	15.	Maintenance tool
6.	12 position servo power turret BMT65	16.	Warning light
7.	10 inch solid hydraulic chuck	17.	Chip conveyor and trolley
8.	Tool holder	18.	Transformer
9.	hydraulic tailstock	19.	3-color signal
10.	Live center	20.	Buzzer

Standard accessories

1	Allen wrench 14(M16)	9	Single head open wrench 50(M33)
2	Allen wrench 3(M4)	10	Phillips screwdriver 6 inch
3	Allen wrench 4(M5)	11	Flat screwdriver 4 inch
4	Allen wrench 5(M6)	12	Flat screwdriver 2 inch
5	Allen wrench 6(M8)	13	U plate(8GB)
6	Allen wrench 8(M10)	14	Adjustable wrench 12 inch
7	Allen wrench 10(M12)	15	Double end wrench 14×17
8	Single head open wrench 30(M20)	16	Sheet metal glue

D. Purchased Components list

No.	Name	Maker
1	Control system	(JP)FANUC
2	X/Z axis ball screw	(TW)PMI
3	Spindle bearing	(JP)NSK
4	Ball screw bearing	(GE)FAG
5	Chuck and cylinder	(TW)STRONG
6	Servo power turret	(TW)LIOSHING
7	Main components of pump and valve	(TW)HP
8	Main components of lubrication system	(CN)LIUBIAN
9	Main electronic components	(FR)SCHNEIDER
10	Coupling	(JP)Mikipulley
11	Water tank pump	(CN)YUNHAI
12	Towline	(CN)WEYER
13	Live center	(KR)GG
14	Chip conveyor	(CN)TONGLE
15	Timing belt	(US)GATES
16	V belt	(JP)SAKAE

Note: According to delivery/technical improvement and other reasons, the suppliers reserve the right to change brands.

E. Installation Preparation Form

No	Item	Request
Machine Basic Requirements		
1	Machine Tool Foundation	The concrete layer is about 350mm thick on hard ground
		No vibration source around the foundation
		No cracks and depressions, no need for additional foundation and grouting
2	Incoming Power Supply Preparation	3-phase 380V; 50±1 Hz, 35kVA(Standard)
		The user provides the power cord from the power supply to the machine tool
3	Compressed air connection preparation (Air gun, Gas pipeline)	Compressed air: $\cong 0.5\text{MPa}$ The user provides a $\text{Ø}10$ air pipe from the air source to the machine
4	Cleaning oil	10L of gasoline or kerosene, some cotton rags
5	Lubricating oil and cutting fluid	Read " Recommended Oil and Grease" for details.
* Machine tools need to be confirmed before leaving the factor *		
6	Transport condition confirmation	Confirm the mode of transportation according to the plant and surrounding road conditions
7	Factory door size	Satisfy the net transport size of the largest part of the machine
8	Factory height	Confirm the lifting method according to the actual height of the plant
9	Spreader preparation	Read the list for details
10	Forklift size	Require a Forklift of more than 8 tons, Forklift arm is larger than 1.8m
11	Unpacking installation assistant	The customer packs box removal and inventory
12	Measuring tool preparation	Check in accordance with the preparation checklist agreed in the contract

13	Acceptance test preparation	Check in accordance with the preparation checklist agreed in the contract
----	-----------------------------	---

If all the items in this form are known and ready, please send it to the manufacturer by fax as follows. If all the items are confirmed, the manufacturer will not be liable for any problems caused by failure to follow the above instructions. Please indicate if there is any special instructions when you send back.

F. Recommended Oil and Grease Tables

Lubrication part	Name	Capacity	Viscosity	Note
Hydraulic unit	Hydraulic oil	45L	ISO VG32	According to the oil level alarm signal provided by the machine tool
	Recommended Brand(Any choice)	HNK-10#		
		Shell Tellus S2 MX 32		
Box guideway, ball screw lubrication	Guideway oil	3L	ISO VG68	According to the situation of the machine, suggesting replace once a year
	Recommended Brand(Any choice)	HNK-2#		
		Shell TONNA S2 M 68		
Cutting coolant		200L		Supply according to the “oil level indication” of the water tank level gauge

If all the items in this form are known and ready, please send it to the manufacturer by fax as follows. If all the items are confirmed, the manufacturer will not be liable for any problems caused by failure to follow the above instructions. Please indicate if there is any special instructions when you send back.

G. Acceptance accuracy table

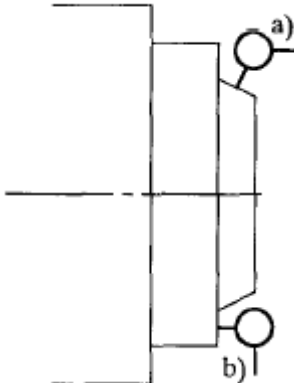
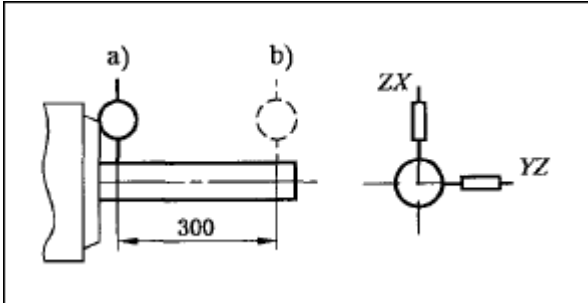
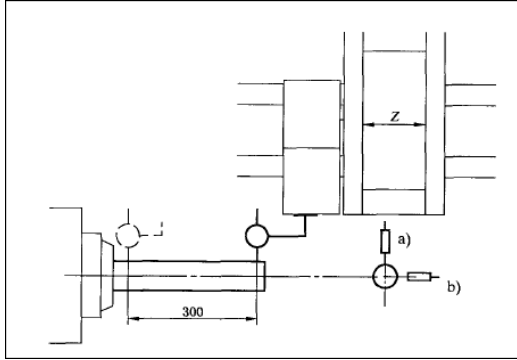
NO	Items	Schematic diagram	Allowable error
1	Spindle nose: A: Radial runout of center journal B: Runout of spindle end face		a : 0.006 b : 0.008
2	Radial runout of spindle shaft hole: a) Near the end of the spindle b) 300mm away from the end of the spindle		a: 0.012 b: 0.015 L=300
3	Parallelism of Z-axis movement (saddle movement) to the spindle axis: a) In the XZ flat b) In the YZ flat		a: $\frac{0.015}{300}$ b: $\frac{0.020}{300}$

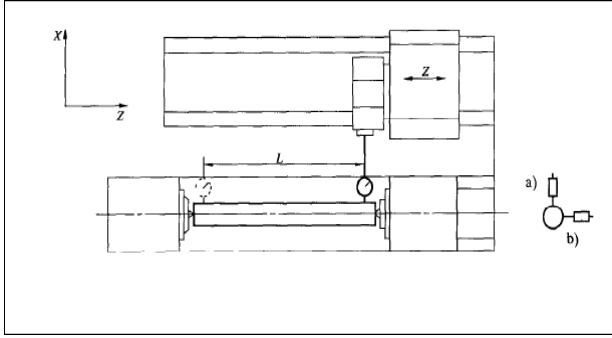
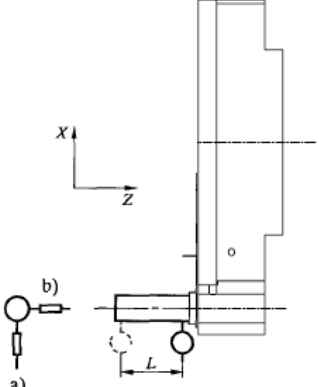
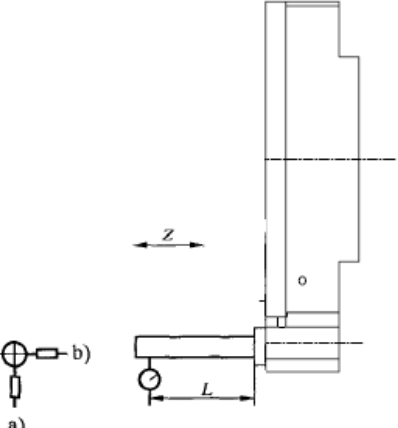
NO	Items	Schematic diagram	Allowable error
4	Parallelism of Z axis movement to turning axis: a) In the ZX flat b) In the YZ flat		a: 0.015 b: 0.03 L=1000(Z axis stroke is less than 1000mm)
5	Parallelism of the axis of the tool holder to the Z-axis movement: a) In the XZ flat b) In the YZ flat		a: 0.020 b: 0.020 L=100
6	Repeated positioning accuracy of tool post indexing: a) In the YZ flat b) In the ZX flat		a: 0.008 b: 0.008 L=100

CNC lathe TC25 II × 1000

(FANUC-0i TF-β5×4500rpm)

(Version: 20220225)

Technical File

宁波海天精工股份有限公司
NINGBO HAITIAN PRECISION MACHINERY CO., LTD.

Content

Technology Agreement including the followings:

A.	Main Features.....	1
B.	Main technical parameters	3
C.	Machine configuration	4
D.	Purchased Components list	5
E.	Installation Preparation Form	6
F.	Recommended Oil and Grease Tables	7
G.	Acceptance accuracy table	8

H. Main Features



(notice: the picture only for reference)

- Double row cylindrical roller bearings and high speed thrust angular contact ball bearings are adopted in the front of the spindle, and double row cylindrical roller bearings are adopted in the rear
- 45 ° one-piece casting lathe bed with box way
- Independent tailstock, hydraulic drives sleeve
- 12 station hydraulic turret
- The motor directly drives ball screw, with pre-stretching
- Thin oil lubrication
- Full enclosure
- **Power & Torque**

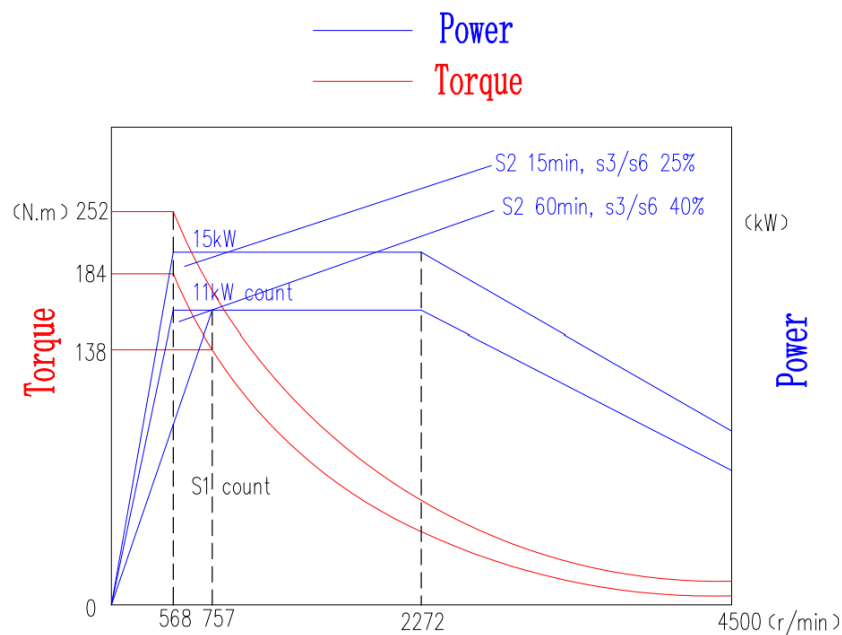

- **Installation conditions**

1. Temperature

Working temperature: 17°C~25°C, ±2°C

If the requirements of the processed parts are not so precision, the ambient temperature range could be relaxed to.

When storing and transporting: -30°C~50°C

2. Humidity

Continuous: Under 75%(No condensation)

Short time: Under 95%(No condensation)

3. Installation site conditions

- 1). Not affected by external vibration and electrical interference

- 2). Avoid direct sunlight to the machine tool

- 3). Avoid direct contact with outside wind, air, and temperature-adjusted cold and hot air

- 4). Avoid setting up heating and other heat sources near the machine tool

- 5). The concentration of dust in the air shall not be greater than 10mg/m³, and should not contain acid, salt and other corrosive gases.

- 6). Avoid water leakage and flooding

I. Main technical parameters

Item			Parameters
Machining scope	Max. swing over the bed	mm	Φ560
	Max. swing over the saddle	mm	Φ320
	Max. turning dia	mm	Φ400
	Max. turning length	mm	1000
	Spindle center according to height	mm	980
	X stroke	mm	210
	Z stroke	mm	1050
Power turret	Turret type	-	Hydraulic V12
	OD size	mm	25×25
	ID size	mm	Φ40
	Indexing time(T-T)	s	0.55
Spindle	Drive type	-	Belt spindle
	Max. spindle speed	rpm	4500
	Power (Con./15 minutes)	kW	11/15
	torque(Con./15 minutes)	mm	138/252
	Spindle nose	-	JISA2-6
	Spindle through hole	mm	Φ62
	Max. bar capacity	mm	Φ50
	Spindle bearing dia(front)	mm	Φ100
Chuck size	inch	8	
Feed	X/Z rapid feed	m/min	24/30
	X/Z servo motor power	kW	1.8/1.8
Tailstock	Quill dia	mm	Φ100
	Center type	-	MT NO.4
	Quill stroke	mm	120
	Stroke	mm	730
Positioning accuracy (GB/T16462.4-2007)	X axis	mm	0.008
	Z axis	mm	0.012
Repeat positioning accuracy (GB/T16462.4-2007)	X axis	mm	0.005
	Z axis	mm	0.008
Controller			FANUC 0i-TF(β5)
Power supply		kVA	25
Water tank capacity		L	250
Machine weight		t	5
Machine size (Length×width×height)		mm	4600×2050×1900

J. Machine configuration

Standard configuration

1.	Controller: FANUC Oi TF	11.	Foot switch
2.	Hydraulic system	12.	Working light
3.	Cutting coolant system	13.	Door interlock
4.	Lubrication system	14.	Leveling blocks
5.	Full enclosure with top cover	15.	Maintenance tool
6.	12 position hydraulic turret	16.	Warning light
7.	8 inch solid hydraulic chuck	17.	Chip conveyor and trolley
8.	Tool holder	18.	Transformer
9.	hydraulic tailstock	19.	3-color signal
10.	Live center	20.	Buzzer

Standard accessories

1	Allen wrench 14(M16)	9	Single head open wrench 50(M33)
2	Allen wrench 3(M4)	10	Phillips screwdriver 6 inch
3	Allen wrench 4(M5)	11	Flat screwdriver 4 inch
4	Allen wrench 5(M6)	12	Flat screwdriver 2 inch
5	Allen wrench 6(M8)	13	U plate(8GB)
6	Allen wrench 8(M10)	14	Adjustable wrench 12 inch
7	Allen wrench 10(M12)	15	Double end wrench 14×17
8	Single head open wrench 30(M20)	16	Sheet metal glue

K. Purchased Components list

No.	Name	Maker
1	Control system	(JP)FANUC
2	X/Z axis ball screw	(TW)PMI
3	Spindle bearing	(JP)NSK
4	Ball screw bearing	(GE)FAG
5	Chuck and cylinder	(TW)STRONG
6	Hydraulic turret	Taiwan Brand
7	Main components of pump and valve	(TW)HP
8	Main components of lubrication system	(CN)LIUBIAN
9	Main electronic components	(FR)SCHNEIDER
10	Coupling	(JP)Mikipulley
11	Water tank pump	(CN)YUNHAI
12	Towline	(CN)WEYER
13	Live center	(KR)GG
14	Chip conveyor	(CN)TONGLE
15	Timing belt	(US)GATES
16	V belt	(JP)SAKAE

Note: According to delivery/technical improvement and other reasons, the suppliers reserve the right to change brands.

L. Installation Preparation Form

No	Item	Request
Machine Basic Requirements		
1	Machine Tool Foundation	The concrete layer is about 350mm thick on hard ground
		No vibration source around the foundation
		No cracks and depressions, no need for additional foundation and grouting
2	Incoming Power Supply Preparation	3-phase 380V; 50±1 Hz, 25kVA(Standard)
		The user provides the power cord from the power supply to the machine tool
3	Compressed air connection preparation (Air gun, Gas pipeline)	Compressed air: $\cong 0.5\text{MPa}$ The user provides a $\text{Ø}10$ air pipe from the air source to the machine
4	Cleaning oil	10L of gasoline or kerosene, some cotton rags
5	Lubricating oil and cutting fluid	Read " Recommended Oil and Grease" for details.
* Machine tools need to be confirmed before leaving the factor *		
6	Transport condition confirmation	Confirm the mode of transportation according to the plant and surrounding road conditions
7	Factory door size	Satisfy the net transport size of the largest part of the machine
8	Factory height	Confirm the lifting method according to the actual height of the plant
9	Spreader preparation	Read the list for details
10	Forklift size	Require a Forklift of more than 6 tons, Forklift arm is larger than 1.8m
11	Unpacking installation assistant	The customer packs box removal and inventory
12	Measuring tool preparation	Check in accordance with the preparation checklist agreed in the contract
13	Acceptance test preparation	Check in accordance with the preparation checklist agreed in the contract

If all the items in this form are known and ready, please send it to the manufacturer by fax as follows. If all the items are confirmed, the manufacturer will not be liable for any problems caused by failure to follow the above instructions. Please indicate if there is any special instructions when you send back.

M. Recommended Oil and Grease Tables

Lubrication part	Name	Capacity	Viscosity	Note
Hydraulic unit	Hydraulic oil	45L	ISO VG32	According to the oil level alarm signal provided by the machine tool
	Recommended Brand(Any choice)	HNK-10#		
		Shell Tellus S2 MX 32		
Box guideway, ball screw lubrication	Guideway oil	3L	ISO VG68	According to the situation of the machine, suggesting replace once a year
	Recommended Brand(Any choice)	HNK-2#		
		Shell TONNA S2 M 68		
Cutting coolant		200L		Supply according to the “oil level indication” of the water tank level gauge

If all the items in this form are known and ready, please send it to the manufacturer by fax as follows. If all the items are confirmed, the manufacturer will not be liable for any problems caused by failure to follow the above instructions. Please indicate if there is any special instructions when you send back.

N. Acceptance accuracy table

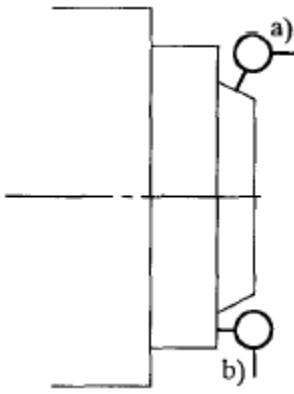
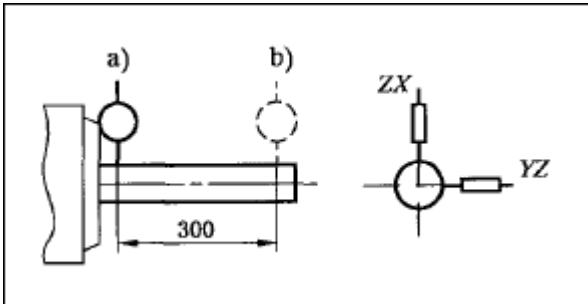
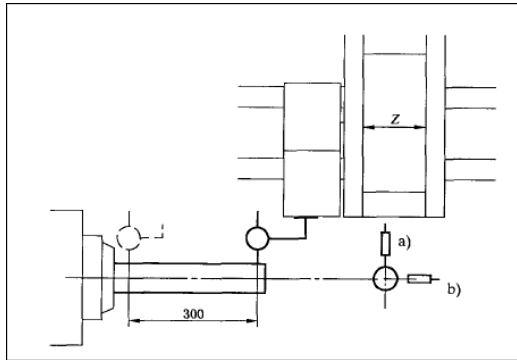
NO	Items	Schematic diagram	Allowable error
1	Spindle nose: A: Radial runout of center journal B: Runout of spindle end face		c : 0.005 d : 0.007
2	Radial runout of spindle shaft hole: a) Near the end of the spindle b) 300mm away from the end of the spindle		a: 0.012 b: 0.015 L=300
3	Parallelism of Z-axis movement (saddle movement) to the spindle axis: c) In the XZ flat d) In the YZ flat		a: $\frac{0.012}{300}$ b: $\frac{0.015}{300}$

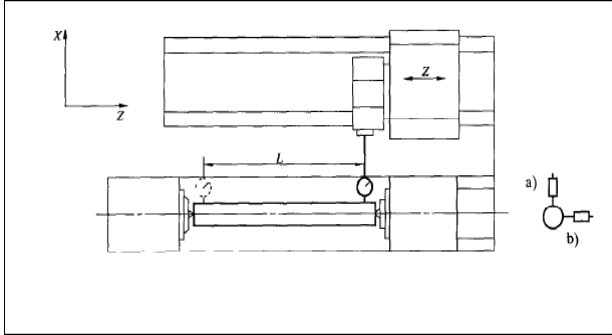
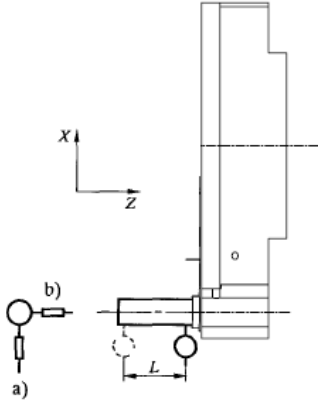
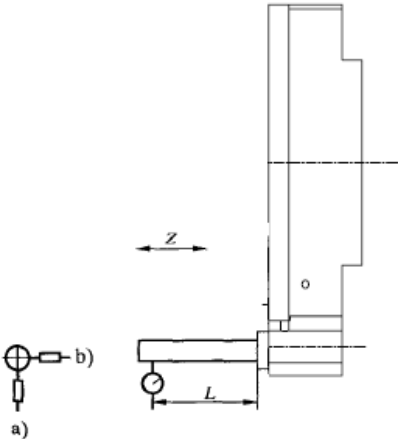
NO	Items	Schematic diagram	Allowable error
4	Parallelism of Z axis movement to turning axis: c) In the ZX flat d) In the YZ flat		a: 0.015 b: 0.02 L=500(Z axis stroke is less than 1000mm)
5	Parallelism of the axis of the tool holder to the Z-axis movement: c) In the XZ flat d) In the YZ flat		a: 0.020 b: 0.020 L=100
6	Repeated positioning accuracy of tool post indexing: c) In the YZ flat d) In the ZX flat		a: 0.008 b: 0.008 L=100